

PRATICA PLUS

Technical specification



EN

Code: FMSTPRP0-021EN
Edition: 07/10/2021

Version 21.1

Copyright © 2018 BOTTERO S.p.A. All rights reserved.

we • glass

NUMERICALLY CONTROLLED MACHINING CENTRE

MAIN CHARACTERISTICS OF THE MODEL PRATICA PLUS FOR GLASS

Numerically controlled machining centre specifically designed for processing sheets of glass equipped with automatic tool changer.

Pratica Plus is available in the versions

(for details see technical data table at the end of the document):

- Size 2500
- size 3300
- size 4000

The standard version of the machine is able to perform the following operations on glass sheets:

- Milling on the sheet with a rectilinear and/or curvilinear path;
- Edging and radial polishing on a straight and/or curved path on the edge of the sheet;
- Drilling and/or countersinking perpendicular to the surface of the sheet;
- Writing and drawing on the top side of the sheet.

By using optional aggregates the possibilities are expanded to:

- Cutting with a straight diamond disc;
- Cutting with a straight diamond disc angled at 45°;
- Writing and drawing on the side surface of the sheet;
- Straight and/or curved beveling on the top side of the sheet;
- Straight and/or curved engraving on the top side of the sheet;
- Straight and/or curved cup grinding on the side surface of the sheet;
- Drilling on the underside of the sheet.

The machine is basically made up of:

- Machine base with a steel structure incorporating the work table;
- Steel mobile beam with the machining head located on the front;
- Machining head with electro spindle and interpolated movement on 3 or 4 axes (optional) (X = length, Y = width, Z = height, C = rotation);
- Aluminium working table;
- Tools-holder magazine fitted at the side of the work table;
- System for clamping the glass sheet on the work table by means of vacuum suction cups (with maintenance-free liquid circuit vacuum pump) and with the aid of telescopic stops for correct positioning (supplied with the machine);
- Electrical cabinet and control pulpit built into the machine structure;
- Safety guards and system designed to be fully compliant with machine Directive 2006/42/CE (CE marking);
- Controlled axes moved by computerized numerical control (CNC);
- Man-machine interface and machining programming software on personal computer (PC) in Windows platform.

MECHANICAL STRUCTURE AND AXIS MOVING

Structure of the machine

- Mobile bridge type, with the main elements in structural steel;
 - Painted parts have three coats applied: an initial acrylic basecoat, a second embossing coat, and lastly a final acrylic enamel top coat, with a dry film thickness varying from 130 μ to 210 μ , to make the structure as waterproof as possible;
 - The parts mostly in contact with water are in stainless steel;
 - The sliding guides of the various machine axes are above the water line and protected from spray by means of bellows;
 - The work table consists of a sheet of a series of aluminium extruded bars bolted to the base of the machine, which can be ground as required by the machining head;
- Base, beam and moving parts have been designed taking advantage of the most modern methods of computerized structural, vibration and thermal analysis based on FEM methodology (*Finite Element Method*).

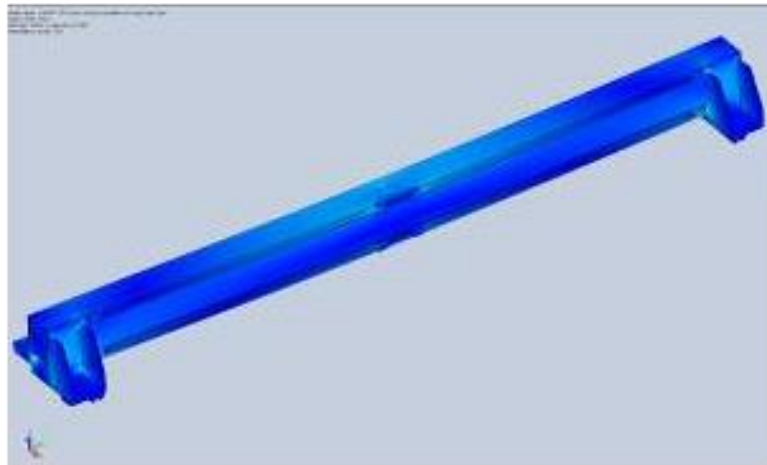

HARDWARE AND SOFTWARE STRUCTURE

The control system for moving the digital axes of the machine uses an industrial computerized numerical control (CNC Osai series Open) dedicated exclusively to this purpose.

Man-machine interface (HMI) and machine process programming (CAD-CAM) are instead performed on a standard PC.

CNC and PC are connected by LAN network.

The separated control architecture between machine management and user interface allows the system to be extremely reliable and immune to instability problems of the system, virus.

All the major electrical and electronic components are enclosed in an electrical cabinet which is IP55 sealed, provided with a suitable ventilation system to control the internal temperature.



Man-machine interface (HMI) - Technohuman

- The machine operating software program is in Windows platform;
- available in operator language (including all CE languages), personalized translations can also be entered;
- Measurement units: metric and Imperial;
- Most of the information and controls are in graphic form making them extremely intuitive;
- The interface is furthermore divided up into various areas, each one dedicated to a particular set of functions (for example manual movements, machining program start up, tool table, origins table);
- Surfing between the different software pages thanks to the “tab menu” structure;
- Virtual simulator to test the machining program with either the machine stopped or in “idle cycle” in order to find and, if necessary, correct any error of programming and/or tool setup on the work table;
- Interface designed to be used with the touch screen monitor (option on request).



Remote Service

This software can also be installed in any office PC connected to the machine in LAN, Wireless or by Internet, so that it can be controlled and supervised at a distance.

The interface also features a Web Cam area complete with audio connection for Bottero technicians for remote assistance.

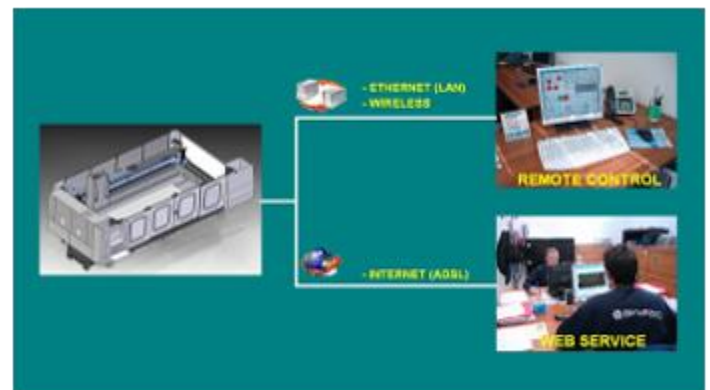

Software for programming the machining operations (CAD/CAM) – Technocad

Windows based software divided into two sections: a CAD part for drawing and a CAM section for programming the tools.

CAD module

- main geometrical drawing functions (lines, arcs, segments) and advanced ones (splines);
- Editing tools (trims, fillets);
- DXF files import;
- Pre-loaded library of parametric figures (pre-drawn shapes of which only the dimensions need to be defined).



CAM module

- intuitive interface to define which parts are to be machined (including all of them) and in which way;
- tools selection depending on the selected machining operation;
- preset working parameters which can be modified according to individual needs;
- Working sequences database, including the customizations already made;
- automatic generation of machining program (ISO program).

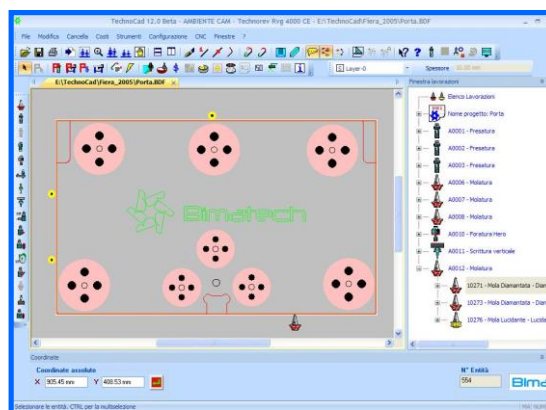

Other functions

- simulating the tool path (useful for avoiding errors on the piece when it is being machined);
- calculating the working times and costs (useful for finding the cost of what is being produced).

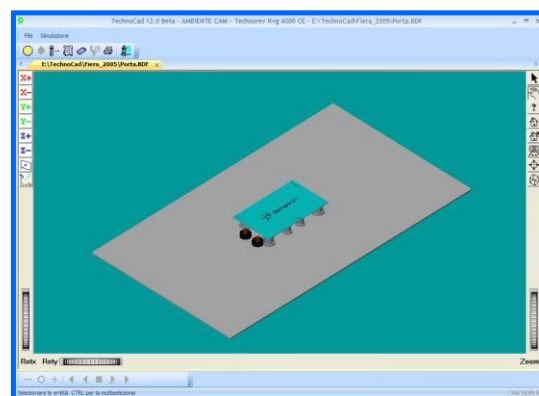

MAIN PERFORMANCE AND STANDARD ACCESSORIES

Electro-spindle

Electro-spindle including:

- self-ventilated air cooling;
- pressurized circuit to prevent leakage of potentially dangerous pollutant particles;
- water distributor for the flow of the “internal” tool cooling water especially useful for increasing the machining performance;
- “External” water distribution system (automatically filtered recycled water) supplied from special nozzles around the

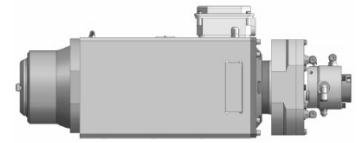

Main data:

Torque/power in S1 mode (continuous service)	30,3 Nm / 9.2 kW
Torque/power in S6 mode (intermittent service)	36,4 Nm / 11 kW
Rotation	100 to 10000 rpm

Tools storages

One easily accessible tools storage located on one side of the machine is supplied as standard: fixed type (model 2500 - 3300) or retractable type (model 4000 and optional on model 2500 - 3300).

The machine can also be equipped with a second optional magazine with the same number of positions as the standard one..



Lubrication

The machine is equipped of Automatic lubrication system managed by the numerical control. The solution is completed by a pump for topping up the grease tank.



Sheet clamping system

Sheet clamping system on the work table consisting in:

- Vacuum cups of different types so to be able to adapt to a wide range of different shapes to be processed; the vacuum cups are symmetric and therefore can be used in both directions (upside-down);
- retracting telescopic stops to facilitate sheet positioning before machining;
- measures aimed at preventing ice from forming in the pipelines even at the lowest temperatures of use;
- clamping circuits activated by manual control levers;
- second clamping circuit and automatic pedal command (optional);

The vacuum system consisting in:

- impeller-type liquid pump requiring no maintenance;
- buffer tank to compensate for variations in the level of vacuum due to sudden drops in the electrical power supply or also machine stoppages for work breaks (the sheet remains properly secured in place until machining is resumed).

The suction cups and stops are in turn secured to the work table (smooth and without any grooves of any type) again by means of a vacuum circuit, being connected to another dedicated circuit in which the vacuum is always present. Because of the smooth work table with no grooves there are no limitations of any kind for positioning the suction cups and stops on it.



Drilling bit dresser + software program

Drilling bit dresser + software program to allow the automatic redressing of drill bits.

N.B. In some conditions this device could reduce the dimensions of the maximum processable sheet.



Cleaning edge kit for polishing wheels + software program

Cleaning edge kit for polishing wheels + software program to allow the automatic removal of the exceeding material on the edges of polishing wheels.

N.B. In some conditions this device could reduce the dimensions of the maximum processable sheet.



Monitoring sensors:

Monitoring sensors:

- water flow;
- vacuum level;
- tools presence (only with retractable storage);

Additional selector to override the axis so to allow an easier control of their speeds.



CE marking

The machine has been designed to comply fully with the current applicable safety standards (Directive 2006/42/CE). It is equipped with suitable safety barriers in heat moulded material, has no danger areas that can be accessed by the operator and is complete with a dual-channel emergency circuit (redundant) with a dedicated safety control box and suppression filters for electromagnetic compatibility.









BASIC EQUIPMENT SUPPLIED AS STANDARD

Q.ty	Code	Description
1		ISO 40 tool-holder cone for stops positioning.
2	BPR129	Suction cups (diameter 90 mm. - h. 140 mm).
2	BPR130	Suction cups (diameter 120 mm. - h. 140 mm).
4	BPR131	Suction cups (diameter 160 mm. - h. 140 mm).
3	BPR132	Telescopic retractable stops.
1		Vacuum tank.
1		Cone holder bracket for tools locking/unlocking.
---	---	---
1		Technical documentation.
2		Technocad software license.
1		PC IBM compatible with latest generation operative system







For more stops, suction cups, tool-holder cones and tools, see the next optional accessories paragraph.



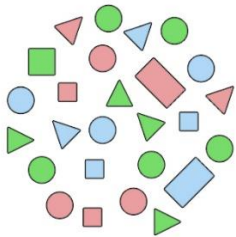

OPTIONAL ACCESSORIES

Code	Description	
BPR119	<p>“Start-up” kit to allow the first use of the machine, including:</p> <ul style="list-style-type: none"> • No. 2 ISO 40 tool-holder cones – threaded hole 1/2“ GAS (BPR127); for routing and drilling bits; • No. 3 ISO 40 tool-holder cones shaft Ø 22 mm, height 34 mm (BPR126); • No. 1 Diamond routing bit Ø 20 mm; • No. 1 Drill bit Ø 22 mm; • No. 1 Diamond Wheel - Segmented Flat Edge Profile - Glass Thickness 10 mm - Ø100 mm; • No. 1 Diamond Wheel - Fine Grit - Trapezoidal Profile - Glass Thickness 10 mm - Ø100 mm; • No. 1 Polishing Wheel - Flat Edge Profile - Glass Thickness 10 mm - Ø100 mm;; 	
BPR126 BPR127	<ul style="list-style-type: none"> • Tool holder cones ISO 40 to use any kind of tools with standard fitting; available in 2 types • shaft Ø 22 mm, height 34 mm [BPR126]; • threaded hole 1/2“ GAS [BPR127]; 	
BPR128 BPR129 BPR130 BPR131 BPR159	<p>Suction cups for glass sheet clamping on machine table with vacuum system, available in 4 sizes:</p> <ul style="list-style-type: none"> • diameter 65 mm [BPR128]; • diameter 90 mm [BPR129]; • diameter 120 mm [BPR130]; • diameter 160 mm [BPR131]. • diametro 150 mm telescopic (BPR159). 	
BPR132	<p>Telescopic retractable stop for correct positioning of glass sheet on machine.</p>	
BPR151	<p>Offset lug (telescopic retractable stop) for correct positioning of glass sheet on machine.</p>	





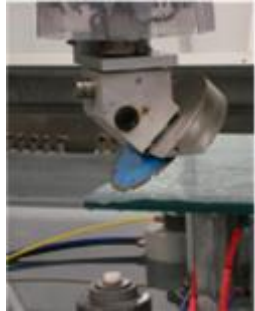

Code	Description	
BTR153	Water pump for the tool external water circulation to be matched with the collecting tank or as an aid to a central water purification system.	
BTR154	Water tank is a water collecting tank to be matched with the water pump.	
BPR118	Laser pre-setter fitted on board machine for measuring tool diameters and length directly on the machine and automatically during machining. <i>NB: In some conditions this device could reduce the dimensions of the maximum processable sheet.</i>	
BCG116	Additional (4th) rotating axis ('C' = RVG) for using aggregates + software (4th interpolating axis with unlimited rotation) for using aggregates that extend the type of machining operations possible. <i>NB: In some conditions this device could reduce the dimensions of the maximum processable sheet.</i>	
BPR145 BCG110 BPR135	PVC working table as an alternative to the aluminium working table for a longer durability and an easier cleaning of the working area BPR145 (2500) _ BCG110 (3300) _ BPR135 (4000)	
BPR148 2500 BPR122 3300	Left mobile tools storage in alternative to the fixed one as supplied as standard. In this way, there is a wider availability of working area. The number of positions for tools is the same as the fixed magazine.	
BPR149 2500 BPR123 3300	Additional right mobile tools storage - add to BPR148 or BPR122 in order to double the standard tool magazine number of positions (see the technical data table at the end of the document). <i>NB: In some conditions this device could reduce the dimensions of the maximum processable sheet.</i>	

Code	Description	
BPR124 4000	<p>Additional right mobile tools storage with 18x positions (15x with 'C' axis) (only for model 4000) in order to double the standard tool magazine number of positions (see the technical data table at the end of the document). <i>NB: In some conditions this device could reduce the dimensions of the maximum processable sheet.</i></p>	
BPR150 2500 BPR143 3300	<p>Additional right mobile tools storage - add to BPR148 or BPR122 in order to double the standard tool magazine number of positions (see the technical data table at the end of the document). <i>NB: In some conditions this device could reduce the dimensions of the maximum processable sheet.</i></p>	
BPR121	<p>Vacuum system with 2 areas for easy locking on working table of more glass sheet at the same time.</p>	
BCG109	<p>Sheet locking system activated by pedal for a faster and easier activation of the vacuum locking system.</p>	
BCG102	<p>A/C for electrical cabinet particularly suitable for machines installed in warm countries or expected to work on multiple shifts per day.</p>	
BPR112	<p>Touch screen monitor useful to facilitate the data setting in addition to the traditional alphanumeric keyboard and mouse.</p>	
BTR156	<p>Remote control (push buttons) for manual axis control (Teach Pendant Pocket) for manual remote control of axes without always having to work from the control pulpit (includes BCG114).</p>	
BCG114	<p>Pre-arrangement for remote control (push buttons) Teach Pendant Pocket (BTR156).</p>	

Code	Description	
DYA143	<p>Reading system type 1D e 2D (DATA MATRIX e QR-code) with base software in order to have an automatic selection of working parameters. (Not included software for integration with customer's ERP system).</p>	
BCG118	<p>Light column for indicating the state of activity of the machine (in progress, waiting to be loaded, machine fault).</p>	
BTR155	<p>Shape scanner, laser system for</p> <ul style="list-style-type: none"> • thickness detection; • positioning detection in the machine; • copying two-dimensional shapes; <p>of a sheet of material; as a shapes copier, by an almost automatic procedure, it is possible to scan the profile of a shape made of any material (including a drawn profile) in order to reproduce it accurately on a sheet of glass.</p>	
BTR157	<p>Origin Scanner, laser system in order to recognize the origin of the glass sheet on the work plane. (It's also able to do the shape scanner function like BTR155).</p> <p>Not compatible with BPS112</p>	
BTR158	<p>Pattern Matching: software for fast identification of the shape to be detected. Useful in order to positioning the biggest glass sheets without "telescopic retractable stop" (twined only with BTR155 or BTR157 are installed)</p>	
BPR102	<p>Laser projector for positioning stops and suction cups on the work table to speed up tooling up time.</p>	

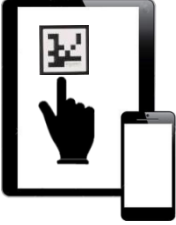
Code	Description	
<p>BPC104 BPC105</p>	<p>Rollers for glass loading (pair) to make loading sheets into the machine easier, especially large ones. (MAX glass sheet 2000x2000mm or 200kg)</p> <p>For size 3300 (BPC104) For size 4000 (BPC105) To be verified with technocal office</p>	
<p>BMW106</p>	<p>ISO 40 kit for writing/decorating the surface of glass panes with a diamond bit comprising:</p> <ul style="list-style-type: none"> • 1 x ISO 40 aggregate for writing bit; • 1 x Writing bit, 4 mm diameter; • Software program. 	
<p>BTR113</p>	<p>ISO 40 kit for circular saw (flat), 200mm disk + software for straight (only with additional rotating axis) comprising:</p> <ul style="list-style-type: none"> • No. 1 ISO 40 aggregate for flat saw blade; • No. 1 continuous diamond disc Ø 200 mm; • Software program. <p><i>NB: For straight cutting only along the Y axis it is not necessary to add the option additional rotating axis.</i></p>	
<p>BTR115</p>	<p>ISO 40 kit for shaped engraving, max diameter 150mm + software for shaped and straight engraving (only with additional rotating axis) comprising:</p> <ul style="list-style-type: none"> • No. 2 ISO 40 aggregates for shaped engraving; • No. 8 Reference stops for piece clamping; • No. 2 "V" profile polishing wheels, Ø 150 mm. 10 thick; • No. 1 "V" profile diamond grinding wheel, Ø 150 10 mm thick; • Software program. <p><i>NB: For straight cutting only along the Y axis it is not necessary to add the option additional rotating axis.</i></p>	
<p>BTR120</p>	<p>ISO 40 kit for cutting 45° (only with additional rotating axis) comprising:</p> <ul style="list-style-type: none"> • 1 x ISO 40 aggregate for 45° cutting; • 1 x Continuous disc diameter 200 mm; • Software program. 	

Code	Description	
BTR116	<p>ISO 40 kit for bevelling 3-5-7-10° + software for straight and/or curved bevelling (only with additional rotary axis) comprising:</p> <ul style="list-style-type: none"> • No. 4 ISO 40 aggregates for bevelling 3°, 5°, 7°, 10°; • No. 2 Metal cup grinding wheel, Ø 150 W5, 80 grit; • No. 1 Resin cup wheel, Ø 150 W15, 120 grit; • No. 1 Resin cup wheel, Ø 150 W15, 1000 grit; • No. 1 Cerium impregnated cup polishing wheel, Ø 150 W22; • No. 1 Cup router Ø 20; • No. 6 Nylon stops H=25; • Software program. <p><i>NB: Kit suitable for bevelling profiles with external angles.</i></p>	
BTR117	<p>ISO 40 kit for mitering 45° (only with additional rotary axis) comprising:</p> <ul style="list-style-type: none"> • No. ISO 40 aggregates for shaped engraving 45°; • No. 2 Metal cup grinding wheel, Ø 150 W5, 80 grit; • No. 1 Resin cup wheel, Ø 150 W15, 120 grit; • No. 1 Resin cup wheel, Ø 150 W15, 1000 grit; • No. 1 Cerium impregnated cup polishing wheel, Ø 150 W22; • No. 1 Cup router Ø 20; • No. 6 Nylon stops H=25; • Software program. <p><i>NB: Kit suitable for bevelling profiles with external angles.</i></p>	
BTR119	<p>ISO 40 kit for horizontal grinding + software for straight and curved grinding with cup grinding wheels (only with additional rotary axis) comprising:</p> <ul style="list-style-type: none"> • No. 4 ISO 40 aggregates for cup grinding; • No. 1 Metal cup grinding wheel, Ø 150 W5, 80 grit; • No. 1 Resin cup wheel, Ø 150 W15, 120 grit, 1°; • No. 1 Resin cup wheel, Ø 150 W15, 1000 grit, 1°; • No. 1 Cerium cup polishing wheel, Ø 150 W22; • (*) No. 3 manual stops; • Software program. 	
BTR112	<p>ISO 40 kit for lower and upper drilling (only with additional rotating axis) comprising:</p> <ul style="list-style-type: none"> • 1 x ISO 40 aggregate for top and bottom drilling; • 1 x Top drilling bit, Ø 22 mm.; • 1 x Bottom drilling bit, Ø 22 mm.; • 1 x Radial vacuum distributor (spider web); • Software program. <p><i>NB: The kit allows to produce holes at a maximum distance of 160mm from the edge of the sheet; moreover the maximum workable dimension of the sheet, considered as the length of the edges perpendicular to that of the holes, reduces by 260mm due to the size of the aggregate</i></p>	

Code	Description	
BTR121	<p>ISO 40 aggregate for writing on the edge of the sheet (only with additional rotating axis) comprising:</p> <ul style="list-style-type: none"> • ISO 40 aggregate for writing on the side surface; • No. 1 writing bit diam. 4 mm.; <p>Software program.</p>	
BTR118	<p>Cerium system (recommended with Kit for 3°, 5°, 7°, 10° bevelling and Kit for 45° bevelling) for improving the polishing quality on bevels.</p>	
BPR158	<p>Augmented reality: Application that uses augmented reality to facilitate diagnosis during machine maintenance and access its documentation by detecting QR-codes from a smartphone or tablet.</p>	
BPC110	<p>Third license of Technocad software (2 are standard).</p>	
ATR103	<p>Power supply unit for mains voltage adaptation</p>	
ATR109	<p>Differential circuit-breaker for 'TT' power supply systems</p>	

General Technical data		2500	3300	4000
Vertical axis (Z)	mm	300		
Vertical axis (C) (optional)		unlimited		
Noise pressure level per indicative work cycle	dB	76,1		
Weight	kg	4100	4180	4800
Working area	mm	2500x1620	3225x1620	3985x2320
Installed machine dimensions		See layout		

Technical data	Without C axis			
	Moving axes X - Y	workable glass sheet with STD lugs stop	workable glass sheet with Offset lugs stop	workable glass sheet without lugs stop
PRATICA PLUS 2500				
Left fixed tools storage	2640 x 1720	2540 x 1570 ⁽¹⁾	2540 x 1620 ⁽¹⁾	2540 x 1620 ⁽¹⁾
Right + left fixed tools storage	2405 x 1720	2305 x 1570 ⁽¹⁾	2305 x 1620 ⁽¹⁾	2305 x 1620 ⁽¹⁾
Left mobile tools storage	2875 x 1720	2570 x 1570 ⁽¹⁾	2670 x 1620 ⁽¹⁾	2775 x 1620 ⁽¹⁾
Right + left mobile tools storage	2850 x 1720	2545 x 1570 ⁽¹⁾	2650 x 1620 ⁽¹⁾	2750 x 1620 ⁽¹⁾
	With C axis			
Left fixed tools storage	2530 x 1720	2430 x 1570 ⁽¹⁾	2430 x 1620 ⁽¹⁾	2430 x 1620 ⁽¹⁾
Right + left fixed tools storage	2055 x 1720	1955 x 1570 ⁽¹⁾	1955 x 1620 ⁽¹⁾	1955 x 1620 ⁽¹⁾
Left mobile tools storage	2875 x 1720	2570 x 1570 ⁽¹⁾	2670 x 1620 ⁽¹⁾	2775 x 1620 ⁽¹⁾
Right + left mobile tools storage	2760 x 1720	2455 x 1570 ⁽¹⁾	2555 x 1620 ⁽¹⁾	2660 x 1620 ⁽¹⁾

(1) with kit preset tools or Wheel Dressing Stick or blade cleaner polishes installed, the dimension 1570 and 1620 will be 1520mm

The “workable glass” data in the table above are defined with a tool of Ø100mm

Technical data	Without C axis			
	Moving axes X - Y	workable glass sheet with STD lugs stop	workable glass sheet with Offset lugs stop	workable glass sheet without lugs stop
PRATICA PLUS 3300				
Left fixed tools storage	3400 x 1720	3300 x 1570 ⁽¹⁾	3300 x 1620 ⁽¹⁾	3300 x 1620 ⁽¹⁾
Right + left fixed tools storage	3165 x 1720	3065 x 1570 ⁽¹⁾	3065 x 1620 ⁽¹⁾	3065 x 1620 ⁽¹⁾
Left mobile tools storage	3635 x 1720	3330 x 1570 ⁽¹⁾	3430 x 1620 ⁽¹⁾	3535 x 1620 ⁽¹⁾
Right + left mobile tools storage	3610 x 1720	3305 x 1570 ⁽¹⁾	3405 x 1620 ⁽¹⁾	3510 x 1620 ⁽¹⁾
	With C axis			
Left fixed tools storage	3290 x 1720	3190 x 1570 ⁽¹⁾	3190 x 1620 ⁽¹⁾	3190 x 1620 ⁽¹⁾
Right + left fixed tools storage	2815 x 1720	2715 x 1570 ⁽¹⁾	2715 x 1620 ⁽¹⁾	2715 x 1620 ⁽¹⁾
Left mobile tools storage	3635 x 1720	3330 x 1570 ⁽¹⁾	3430 x 1620 ⁽¹⁾	3535 x 1620 ⁽¹⁾
Right + left mobile tools storage	3520 x 1720	3215 x 1570 ⁽¹⁾	3315 x 1620 ⁽¹⁾	3420 x 1620 ⁽¹⁾

(1) with kit preset tools or Wheel Dressing Stick or blade cleaner polishes installed, the dimension 1570 and 1620 will be 1520mm.

The “workable glass” data in the table above are defined with a tool of Ø100mm

Technical data	Without C axis			
	Moving axes X - Y	workable glass sheet with STD lugs stop	workable glass sheet with Offset lugs stop	workable glass sheet without lugs stop
PRATICA PLUS 4000				
Left mobile tools storage	4395 x 2420	4090 x 2270 ⁽¹⁾	4190 x 2320 ⁽¹⁾	4295 x 2320 ⁽¹⁾
Right + left mobile tools storage	4370 x 2420	4065 x 2270 ⁽¹⁾	4165 x 2320 ⁽¹⁾	4270 x 2320 ⁽¹⁾
	With C axis			
Left mobile tools storage	4395 x 2420	4090 x 2270 ⁽¹⁾	4190 x 2320 ⁽¹⁾	4295 x 2320 ⁽¹⁾
Right + left mobile tools storage	4280 x 2420	3975 x 2270 ⁽¹⁾	4075 x 2320 ⁽¹⁾	4180 x 2320 ⁽¹⁾

(1) with kit preset tools or Wheel Dressing Stick or blade cleaner polishes installed, the dimension 2270 and 2320 will be 2220mm.

The “workable glass” data in the table above are defined with a tool of Ø100mm

Tools storages		2500	3300	4000
Tool storage type		Fixed	Fixed	Retractable
Without C axis (Without aggregate)	Pos	10 + 10	13 + 13	18 + 18
With C axis (Without aggregate)	Pos	max 8 + 8	max. 11 + 11	max. 15 + 15
Maximum tool diameter	mm	150		
Max weight for single tool in warehouse (NO aggregate)	kg	4.5		

Configuration for each warehouse tools					
2500		3300		4000	
Without aggregate					
Without C axis	With C axis	Without C axis	With C axis	Without C axis	With C axis
10	8	13	11	18	15
N° 1 aggregate					
Without C axis	With C axis	Without C axis	With C axis	Without C axis	With C axis
9 = (8+1)	8 = (7+1)	12 = (11+1)	10 = (9+1)	17 = (16+1)	14 = (13+1)
N° 2 aggregates					
Without C axis	With C axis	Without C axis	With C axis	Without C axis	With C axis
9 = (7+2)	7 = (5+2)	11 = (9+2)	10 = (8+2)	16 = (14+2)	14 = (12+2)
N° 3 aggregates					
Without C axis	With C axis	Without C axis	With C axis	Without C axis	With C axis
8 = (5+3)	7 = (4+3)	10 = (7+3)	9 = (6+3)	15 = (12+3)	13 = (10+3)
N° 4 aggregates					
Without C axis	With C axis	Without C axis	With C axis	Without C axis	With C axis
7 = (3+4)	6 = (2+4)	10 = (6+4)	9 = (5+4)	14 = (10+4)	13 = (9+4)
N° 5 aggregates					
Without C axis	With C axis	Without C axis	With C axis	Without C axis	With C axis
6 = (1+5)	6 = (1+5)	9 = (4+5)	8 = (3+5)	14 = (9+5)	12 = (7+5)
N° 6 aggregates					
Without C axis	With C axis	Without C axis	With C axis	Without C axis	With C axis
8 = (2+6)	8 = (2+6)	8 = (2+6)	8 = (2+6)	13 = (7+6)	12 = (6+6)
N° 7 aggregates					
Without C axis	With C axis	Without C axis	With C axis	Without C axis	With C axis
---	---	---	---	12 = (5+7)	11 = (4+7)
N° 8 aggregates					
Without C axis	With C axis	Without C axis	With C axis	Without C axis	With C axis
---	---	---	---	11 = (3+8)	11 = (3+8)

Installation and conditions of use		2500	3300	4000
Installed power	kVA	25		
Air pressure use	bar	6,5		
Compressed air consumption	NI/min	350		
Water pressure use	bar	3		
Consumption water	l/min	15		
Flow rate of water	l/min	130		
Power supply		Voltage: 400 V (+/- 10%) 3Ph + PE (TN system) Frequency 50 Hz		
Air characteristic		Compressed air: 6.5 bar, max. 10 bar Filtering: 5 micron Lubrication: without lubrication Dew point = 3°C (room temperature)		
Cooling water characteristic (NOTE: The chemical substances that in solution with the tool cooling water come into contact with the various machine parts, must not for any reason have corrosive characteristics.)	pH	6.5 a 7.5	Acidity/basicity watery solutions	
	ppm	≤ 50	Chlorides (Cl-)	
	LSI	0 a +0.4	Langelier Index(LSI)	
	μS/cm	≤ 400	Conductivity at 20 °C	
	° f	≤ 20	Total hardness	
	mg/l	≤ 250	Fixed residue at 180°C	
	mg/l	≤ 100	Sulphate SO ₄	
	mg/l	≤ 0,5	Nitrites NO ₂	
	mg/l	≤ 1	Nitrates NO ₃	
	mg/l	≤ 0,05	Ammonium NH ₄	
mg/l	≤ 0,5	Iron Fe		
For tool external water	ppm	≤ 100	Solid particles concentration	
	μm	≤ 50	Solid particles size	
For tool internal water	ppm	≤ 30	Solid particles concentration	
	μm	≤ 20	Solid particles size	
	°C	15	Temperature	
Stocking: Temperature and moisture	°C	From - 5° to + 55°, reference pressure 1 bar 90% of relative moisture at 20° C (w/o condensation) 50% of relative moisture at 40° C (w/o condensation)		
Use: Temperature, humidity and altitude	°C	From - 5° to + 40°, reference pressure 1 bar 90% of relative moisture at 20° C (w/o condensation) 50% of relative moisture at 40° C (w/o condensation) Maximum altitude 1000 m (above sea level)		

Electro spindle		2500	3300	4000
Maximum rotation speed	rpm	10.000		
Power in continuous service (S1)	kW	9,2		
Torque in continuous service (S1)	Nm	30,3 fino a 3.000 rpm		
Power in intermittent service (S6)	kW	11,04		
Torque in intermittent service (S6)	Nm	36,4 fino a 3.000 rpm		

Trasport			2500	3300	4000
Dimensions for shipment by sea	Length	mm	Container 20" OT		6560
	Width	mm			2970
	Height	mm			2400
Dimensions for shipment by truck	Length	mm	5030	6.160	6560
	Width	mm	2270	2.450	2970
	Height	mm	2400	2.400	2400

BOTTERO S.P.A. ACCEPTS NO RESPONSIBILITY FOR ANY ERRORS AND RESERVES THE RIGHT TO MODIFY, EITHER WHOLLY OR IN PART, THE TECHNICAL CHARACTERISTICS OF ITS PRODUCTS WITHOUT GIVING ANY PRIOR NOTICE

* SOME DATA ARE VALID ONLY IN CASE THE RELEVANT OPTION IS INCLUDED

PRATICA

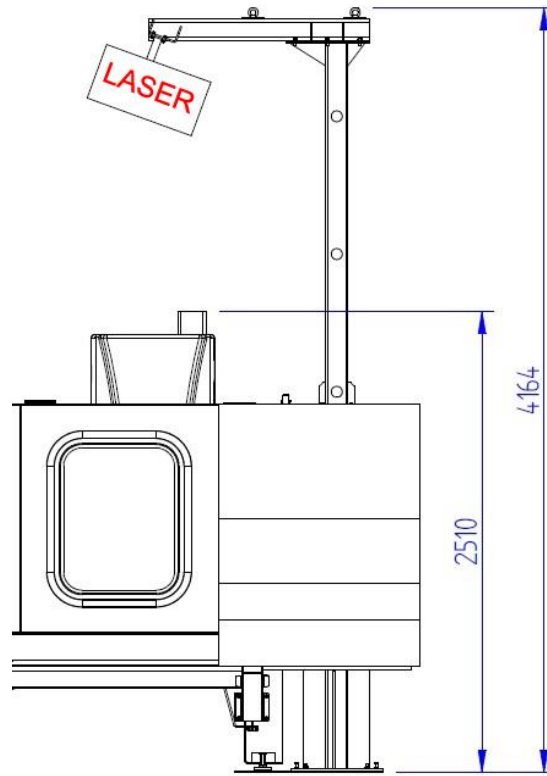

BPR102 Laser position on machine

TABLE 1 (spindle components)	
VEM CODE	DESCRIPTION
C60042RS	BEARING ref. 6004 2RS
C619052RS	BEARING ref. 61905 2RS
CI2515	CYLINDER PNEUMAX 1511.25.15
D04924	PISTON PLUG ECR 16/40 D04924
D06867	REFERENCE TANG NDX16 I4 D06867
DIM22410	SPRING DIM22410
FK6ASD28	RING FEY FK6 ASD 28.5
FK6ASD80	RING FEY ASD 80
FK6ASD85	RING FEY 16010001940 - ASD 85/3,5/1,65
LRC6287/70	RING LUBRORING ref. LRC 6287/70 with OR
MSCM40H1	SPRING SMALLAY CM40-H1
NBM061020	BELT BM FLUOR 6,1 X 2,0
OR008015	RING OR 8,5 X 1,5 metric
OR2056	RING OR 2056
OR2062	RING OR 2062
OR2068	RING OR 2068
OR2093	RING OR 2093
OR3112	RING OR 3112
OR3275	RING OR 3275
OR4036	RING OR 4036
OR4675	RING OR 4675
QR4261	RING QR 4261
RS3242	RING DP7 32.42.7
SF0635I	SPHERE Ø 6,35 ¼ INOX AISI 440 C
SI8PNPNO	SENSOR DCA8/4909KS (NO) - OUTPUT CONNECTOR
SIRSUA	INDUCTIVE SENSOR Pneumax RS.UA
T07488	COMPLETE TIE-ROD GROUP ECR16 BIM D07488
VEX50	COUPLE OF BEARING SNFA VEX50 7CE1 DDL
VEX70	COUPLE OF BEARING SNFA VEX70 7CE3 DD 10 daN

The consumable materials like: grinding tools stone or marble squaring pads, stone or marble reference pads and spindle components like gaskets, bearings, bushings, tip, spindle collet unit, tenons, pop-up joint, etc... (see **TABLE 1**) are not covered by warranty.

For more details and information see the Use and Maintenance manual (SECTION CONSUMABLE MATERIALS) supplied with the machine.

PROJECT AND PRODUCTION STANDARDS

Adopted standards

The machine is designed, built and installed in consideration of the safety standards in force. Importance is placed upon the following aspects:

- Easy approach.
- Workstation ergonomics.
- Easy access to parts requiring maintenance.
- Reliability of the machine and its components.
- Reduced noise levels.
- Power savings.

The following versions are available:

Arrangement in compliance with European Standard and CE
 Guideline 2006/42/CE
 Guideline 2014/30/CE
 Guideline 2009/105/CE

IEC EN 60204-1
 EN ISO 12100

The machine is not compliant to
 UL/CSA Mark



BOTTERO S.p.A.
 Via Genova 82
 12100 Cuneo Italy
 Tel.: +39 0171 310611
 Fax: +39 0171 401611
www.bottero.com